

Service unit 3 part assemblies

FUTURA-SERIES

item	type	KS3U-114/* G	KS3U-138/* G
port size		G 1/4	G 3/8
description		sinter filter, centrifugal principle, Diaphragm-type pressure regulator with secondary air exhaust, Lubricator with automatic oil filling	
medium		compressed air, neutral gases	
mounting		vertical	
medium- and ambient temperature		max. 50 °C	
supply pressure		Pe max. 16 bar Pe min. 1,5 bar semi-automatic and fully automatic drain	
filter element		5 µm Standard	
bowl volume		filter: 28 cm ³ , lubricator: 40 cm ³	
drain model		semi-automatic	
reduced pressure	3	0,5 - 8 bar, 0,1-1 bar, 0,1-2 bar, 0,2-4 bar, 0,5-10 bar, 0,5-16 bar	
oil metering qv=1000 l/min		1 - 2 drops / min	
oil type		CL 32 standardized to DIN 51517 - ISO VG 32	
fixing		control panel installation, mounting bracket, wall mounting	
weight		0,825 kg	

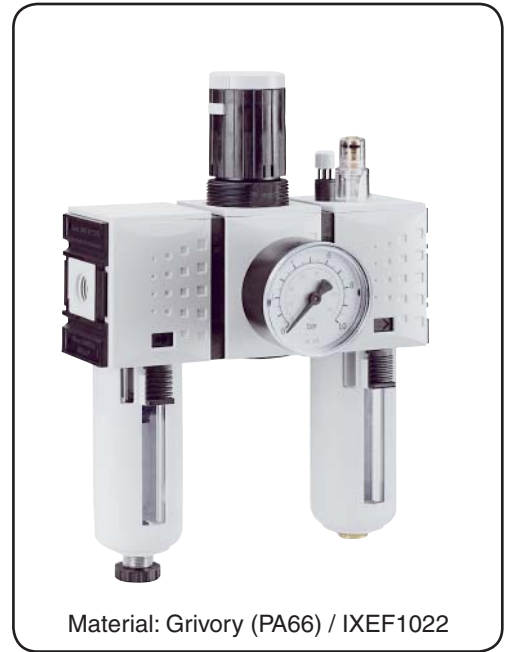

Technical modifications keep on reserve!

parts (Service-Kit: ESA.1-1311)

no.	designation		material	order-no.
1	condensate bowl	BE.1 HA4	polycarbonate	90001.0200
2	filter element 5µm	C.00-26	Cellpor	5.2100.26.000
3	spring cage	BG1	POM	---
4	setting knob	FH.1-625	POM	---
5	spring	FED.1-703	galvanised steel	---
6	membrane	MEM.1	brass-NBR-PA6	
7	valve cone	C.11-79	brass-NBR	
8	spring	FED.1-720	stainless steel	---
9	cover with o-ring 32x2,5	DE.1-300	POM / NBR	---
10	dome assembly	ESA-1-1312	polycarbonate	99901.1312
11	bowl	BE.1 LUB	polycarbonate	90001.0202

application information

- Filter transmittance according to ISO 4003, glass bead test
- Setting knob can be locked by pressing downwards
- Regulator head lockable
- Can be filled with oil during operation



series 1

ordering information

KS3U - * / * ***

type

1 port size

2 accessories

3 reduced pressure

ordering example: KS3U-114/8 AM G

1	port size	
	114	G 1/4
	138	G 3/8
	114 NPT	1/4-18 NPT
	138 NPT	3/8-18 NPT
2	accessories (see reverse side)	
	S	control panel nut
	H	metal bowl with level indicator
	AM	fully automatic drain pressureless open
	AM NC	fully automatic drain pressureless closed
3	reduced pressure (see item table)	
	e.g. 8	0,5 - 8 bar

page: KS3U-1 (01/09)

dimensions (mm)

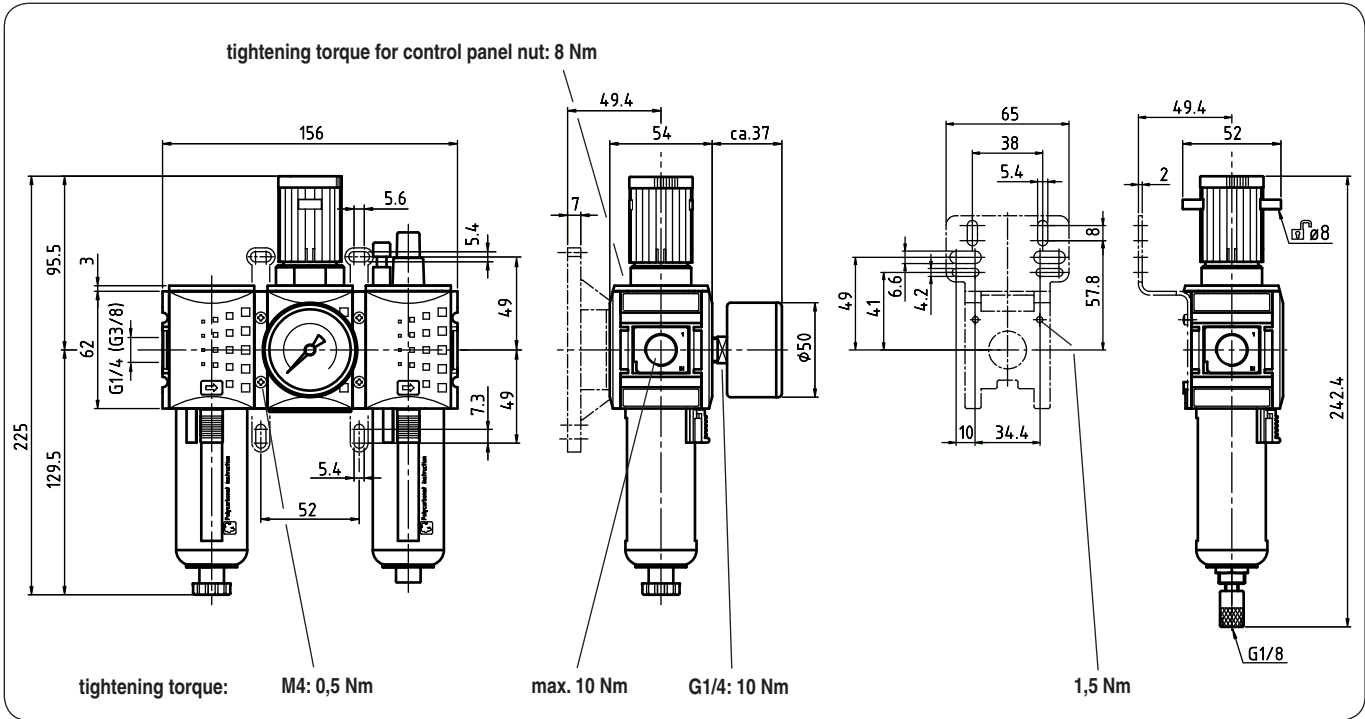

flow characteristic

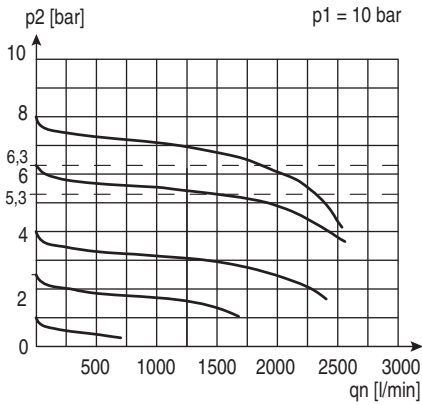

pressure characteristic

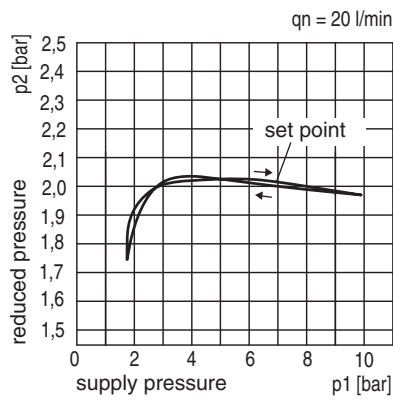

lubricator operating limit

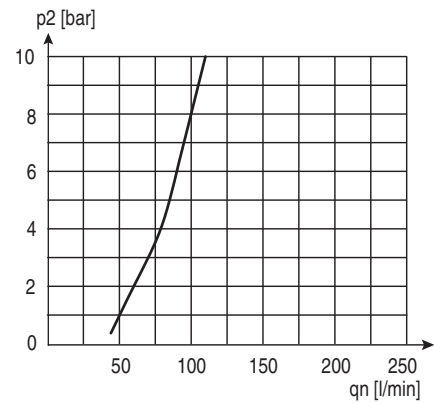

accessories 2

gauge

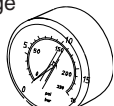

type: G 50.2,5 R
G 50.4 R
G 50.6 R
G 50.10 R
G 50.16 R
G 50.25 R

spring

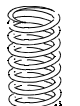

Typ:
0,1- 1: FED.1-700
0,1- 2: FED.1-701
0,2- 4: FED.1-702
0,5- 8: FED.1-703
0,5-10: FED.1-704
0,5-16: FED.1-705

automatic drain

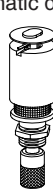

type: AM 10
AM 10 NC

metal bowl with level indicator

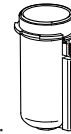

type:
BE.1 H HA
BE.1 H AM
BE.1 H AM NC

lock



Typ:
VH.32 with key
VH.31 without key E11

coupling kit

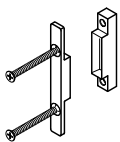

type: KKOP.1

coupling kit wall mounting

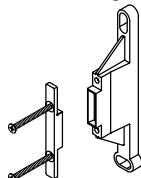

type: KKOP.1W

mounting bracket with screws

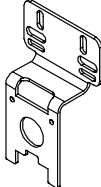

type: KBW.1-1225

mounting bracket for panel installation



type: KBW.1-1227

control panel nut M 36 x 1,5



type: SM.1